

LUBRICATION ORDER

LO 5-1940-221-12

22 OCTOBER 1984

(Supersedes LO 5-1940-221-12-1 and -2 dated 22 February 1974)

**BOAT, BRIDGE ERECTION, INBOARD DIESEL ENGINE, ALUMINUM HULL, 27 FT LG, (ALUMINUM COMPANY OF AMERICA MODEL HICE-27D) (HIGHWAY PRODUCTS MODEL HPI-27C MODDED) ; (HIGHWAY PRODUCTS MODEL HPI-27B MODDED) (MARINETTE MARINE CORP. MODEL A27 MODDED)
NSN 1940-00-417-0526**

Reference TM 5-1940-221-12 and Federal Supply Catalog C9100-1L

Total TASK-HR is the time needed to do all services (on-condition or hard-time) prescribed for a particular interval based on normal operation.

When operating under adverse conditions or if lubricants become contaminated, change your hard-time interval. You may also extend intervals during periods of low activity provided adequate preservation is performed.

The on-condition (OC) oil sample interval shall always apply unless otherwise directed by the Army Oil Analysis Program (AOAP) laboratory. In the event (AOAP) laboratory support is not available, apply your hard-time interval.

Clean fittings before lubricating. Relubricate after washing or fording.

Clean parts with dry-cleaning solvent type II (SO-II) and dry before lubricating.

Authorized level of maintenance symbols, operator/crew (C) and organizational maintenance (O).

A dotted circle indicates a drain below and a dotted arrow indicates points of lubrication on both sides of equipment.

You can help improve this publication. If you find a mistake or know of a way to improve the procedures, please let us know. Mail your letter or DA Form 2028 (Recommended Changes to Publications and Blank Forms) to: US Army Troop Support Command, ATTN: AMSTR-MPS, 4300 Goodfellow Boulevard, St. Louis, MO 63120-1798. A reply will be promptly furnished to you.

TOTAL TASK-HR		TOTAL TASK-HR	
INTERVAL	TASK-HR	INTERVAL	TASK-HR
25	0.3	300	2.0
100	0.3	500	0.4
250	0.2	1000	2.0

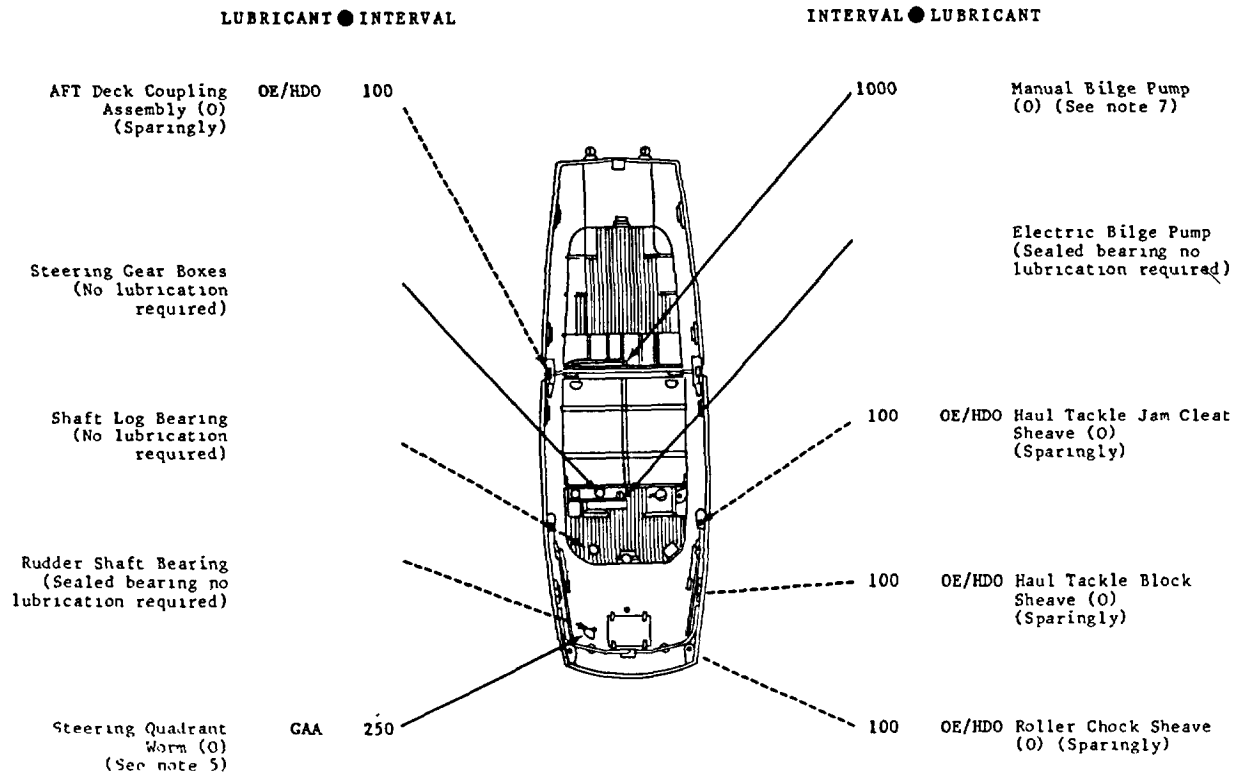

LUBRICANT ● INTERVAL

INTERVAL ● LUBRICANT

Generator
(Sealed bearings, no
lubrication required)

Crankcase Level Gage
(C)(Check level when
boat is in water)

Oil Filter (O)
on-condition
AOAP analysis
(See note 3)

Oil Filter Drain Plug

Engine Speed Control
Linkage (O)

Crankcase Drain (O)
On-condition AOAP
analysis (Attach
sump pump and pump
out oil and refill)
(See note 3)

Transmission Fill,
Drain and Level Cap
(O) (See note 4)
(See key)

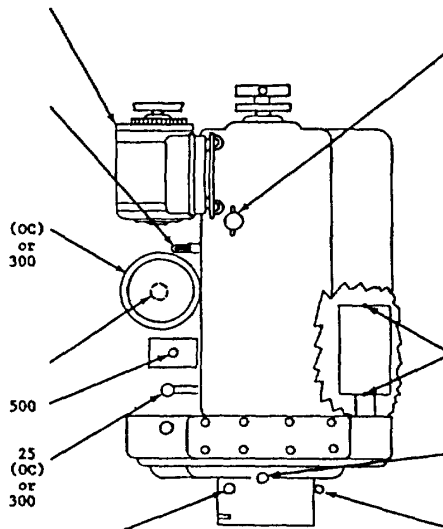

OE/HDO Crankcase Fill Cap (C)
(See key) (Fill only
with boat in water)

500 OE/HDO Starter (O)
(Remove plugs. Lubri-
cate sparingly and
replace plugs)

500 GAA Tachometer Drive (O)

1000 Transmission Strainer
(O) (See note 4)

-KEY-

LUBRICANTS		CAPACITY	EXPECTED TEMPERATURES			INTERVALS
			Above +32°F (Above -0°)	+ 40° F to -10° F (5° to -23°)	0° F to -65° F (-18° to -53°)	
OE/HDO (MIL-L-2104C)	LUBRICATING OIL, Engine			OE/DO 30	For Arctic Operation, Refer to TM 9-207	Intervals given are in hours of normal operation
	Crankcase Oil	9.5 qt (10L) ea				
	Transmission Oil	3 qt (2.8L) ea				
OEA/APG-PD1 (MIL-L-46167)	LUBRICATING OIL, Engine Sub-Zero		OE/HDO 30	OR/HDO 10	OEA	
GAA (MIL-G-10924)	GREASE, Auto and Artillery		ALL TEMPERATURES			

NOTES:

- FOR OPERATION OF EQUIPMENT IN PROTRACTED COLD TEMPERATURE BELOW -10°F (-23°C). Remove lubricants prescribed in the key for temperatures above -10°F (-23°C). Clean parts with SOLVENT, dry-cleaning (SD-II). Relubricate with lubricants specified in the key for temperatures below -10°F (-23°C).
- OIL CAN POINTS. Every 100 hours, lubricate transmission shift linkage, pins, and clevises, and all exposed adjusting threads with OE/HDO.
- CRANKCASE OIL AND FILTERS. Replace on-condition as directed by the Army Oil Analysis Program (AOAP) laboratory. Send a sample of oil for analysis at intervals of 25 hours or 30 days. Refer to TB 43-0210 for sampling. When AOAP laboratories are not available, replace the oil and filters at the hard-time interval of 300 hours or 6 months. Operate for 5 minutes, check for leaks, check oil level, and bring to full mark.
- TRANSMISSION REDUCTION GEAR. Drain by pumping oil from unit. Disconnect hose. Remove strainer, clean, and replace. Fill transmission. Start engine, run at idle for three minutes, stop, check for leaks, check oil level and bring to full mark.

- STEERING QUADRANT. Every 250 hours clean old grease from grease cups and relubricate grease cups and fittings with GAA.
- DO NOT LUBRICATE. Propeller shaft, propeller strut bearing, and rubber shaft bearings.
- MANUAL BILGE PUMP. Lubricate with silicone compound, NSN 9150-00-076-1474, 1/2 oz container every 1000 hours.

Copy of this lubrication order will remain with the vehicle at all times. Instructions contained herein are mandatory.

By Order of the Secretary of the Army:
JOHN A. WICKHAM, JR.
General, United States Army
Chief of Staff
Official:
ROBERT M JOYCE
Major General, United States Army
The Adjutant General

DISTRIBUTION:
 To be distributed In accordance with DA Form 12-25D,
 Operator Maintenance Requirements for Boat Bridge Erection.

